

Analysis of a long-term outbreak of XDR *Pseudomonas aeruginosa*: a molecular epidemiological study

Matthias Willmann^{1,2*}, Daniela Bezdán^{3,4}, Luis Zapata^{3,4}, Hana Susak^{3,4}, Wichard Vogel⁵, Klaus Schröppel¹, Jan Liese^{1,2}, Christopher Weidenmaier^{1,2}, Ingo B. Autenrieth^{1,2}, Stephan Ossowski^{3,4} and Silke Peter^{1,2}

¹Institute of Medical Microbiology and Hygiene, University of Tübingen, Tübingen, Germany; ²German Center for Infection Research (DZIF), partner site Tübingen, Tübingen, Germany; ³Genomic and Epigenomic Variation in Disease Group, Centre for Genomic Regulation (CRG), Barcelona, Spain; ⁴Universitat Pompeu Fabra (UPF), Barcelona, Spain; ⁵Medical Center, Department of Hematology, Oncology, Immunology, Rheumatology & Pulmonology, University of Tübingen, Tübingen, Germany

*Corresponding author. Tel: +49 7071/29-81527; Fax: +49 7071/29-5440; E-mail: will80@gmx.de

Received 1 August 2014; returned 2 November 2014; revised 10 November 2014; accepted 5 December 2014

Objectives: Here we report on a long-term outbreak from 2009 to 2012 with an XDR *Pseudomonas aeruginosa* on two wards at a university hospital in southern Germany.

Methods: Whole-genome sequencing was performed on the outbreak isolates and a core genome was constructed for molecular epidemiological analysis. We applied a time–place–sequence algorithm to improve estimation of transmission probabilities.

Results: By using conventional infection control methods we identified 49 *P. aeruginosa* strains, including eight environmental isolates that belonged to ST308 (by MLST) and carried the metallo- β -lactamase IMP-8. Phylogenetic analysis on the basis of a non-recombinant core genome that contained 22 outbreak-specific SNPs revealed a pattern of four dominant clades with a strong phylogeographic structure and allowed us to determine the potential temporal origin of the outbreak to July 2008, 1 year before the index case was diagnosed. Superspreaders at the root of clades exhibited a high number of probable and predicted transmissions, indicating their exceptional position in the outbreak.

Conclusions: Our results suggest that the initial expansion of dominant sublineages was driven by a few superspreaders, while environmental contamination seemed to sustain the outbreak for a long period despite regular environmental control measures.

Keywords: whole-genome sequencing, transmission analysis, outbreak investigation, IMP carbapenemase

Introduction

Pseudomonas aeruginosa is an opportunistic human pathogen and among the five most common bacteria in healthcare-associated infections in Europe.¹ Of particular concern are the rising rates of antibiotic resistance observed worldwide. In 2012, almost one-third of invasive clinical *P. aeruginosa* isolates in European hospitals were reported to be carbapenem resistant.¹ In the same year, the European Antimicrobial Resistance Surveillance Network (EARS-Net) report from 30 European countries stated that 13.8% of *P. aeruginosa* isolates exhibited an MDR phenotype (MDR-PA).^{2,3} A number of studies reported high mortality rates associated with bloodstream infections due to MDR-PA^{4–6} and an elevated total mean economic cost for nosocomial MDR-PA acquisition (MDR-PA €15 256 versus non-MDR-PA €4933 per patient admission).⁷

This poses a serious problem, particularly in hospitals that are facing long-term outbreaks of *P. aeruginosa*, most likely caused by

widespread environmental contamination.^{8–10} Therefore, it is crucial to fully understand the relevant in-hospital transmission routes in order to apply efficient and effective infection control measures.

One approach to identifying transmission routes is to sample and genotype *P. aeruginosa* isolates during an outbreak and assess genetic relatedness and epidemiological correlations. However, common typing methods, such as PFGE or PCR amplification of non-coding repetitive sequences over the bacterial genome (rep-PCR), cannot provide sufficient discriminatory power for closely related isolates. In contrast, whole-genome sequencing (WGS) provides sufficient genetic resolution for an extended investigation, as shown by recent studies on MRSA, *Mycobacterium tuberculosis* and KPC-producing *Klebsiella pneumoniae*.^{11–15} Additionally, the rapid decrease in costs and turnaround time of WGS will facilitate the integration of this technology into routine diagnostic procedures in the near future and may establish a new standard for infection control measures.

In the present study, we describe a long-term outbreak of XDR *P. aeruginosa* (XDR-PA) on two wards at a university hospital in southern Germany. Information gained by WGS was used to trace previously unsuspected transmission routes to identify superspreaders, and was compared with an outbreak reconstruction obtained by using conventional surveillance methods.

Materials and methods

Study design

Our outbreak reconstruction was based on epidemiological and genetic data. The study was approved by the local research ethics committee of the University of Tübingen (reference number 077/2014R). Clinical and environmental isolates of *P. aeruginosa* collected between July 2009 and March 2012 were submitted for sequencing and further analysis if they were considered to belong to the outbreak by exhibiting an XDR phenotype³ and carrying an IMP-8 gene. Multiple isolates from one patient were included if they were obtained on different days and from different clinical materials.

Bacterial isolation, identification and drug-susceptibility testing

Cetrimide agar (Becton, Dickinson and Company, Le Pont de Claix, France) was used as the screening medium for *P. aeruginosa*. Species were identified using a linear MALDI-TOF mass spectrometer (AXIMA Assurance, bioMérieux, Marcy-l'Étoile, France), supplemented by Vitek 2 system identification (bioMérieux). *In vitro* bacterial susceptibility testing was conducted using the Vitek 2 system (bioMérieux) and interpreted according to the EUCAST guidelines.^{16–18} Colistin susceptibility was measured using the Etest gradient diffusion method and interpreted following CLSI breakpoints.¹⁹ Further Etests were performed to determine the MICs of meropenem, doripenem, fosfomycin and amikacin. Strains were stored at -80°C until analysis.

Library preparation, WGS and genome assembly

Genomic DNA was sheared using a Covaris Focused-ultrasonicator (Covaris, Woburn, USA) to obtain 300–400 bp fragments. DNA libraries were prepared with the TruSeq DNA LT Sample Prep Kit (Illumina, San Diego, CA, USA) with 24 different barcodes using the standard protocol and were sequenced at 2×50 bp on an Illumina HiSeq2000 (Illumina). SOAPdenovo version r1.05 was selected as the assembly tool.²⁰

Genome alignment, variant and transmission analysis

A core genome alignment for all 49 isolates was generated using the progressiveMauve algorithm.²¹ The isolate WGS-E4 exhibited high sequencing and assembly quality and was defined as the outbreak reference genome. It was sampled from an environmental source (siphon water) and considered a circulating hospital strain. Sequences were aligned to the WGS-E4 reference genome with Bowtie 2²² and core genome SNPs were called using the SAMtools package.²³

A transmission from patient A to patient B was assumed to have potentially occurred if the detection of the outbreak strain in patient A preceded the detection in patient B. The probability of a transmission between patient A and B was based on four criteria, including information on time and place for both patients and on variations in the genome sequences of their isolates. This analysis method was named the time-place-sequence (TPS) algorithm. Criterion 1 was considered fulfilled if both patients resided on the same ward with a minimum overlap of 24 h before the outbreak strain was detected in patient B. Criterion 2 was fulfilled if patient B resided in the same room that patient A occupied

up to 2 weeks prior to patient B. Criterion 3 was fulfilled when patient A and B stayed in the same room with a minimum overlap of 24 h before the outbreak strain was detected in patient B. Close genetic relatedness between strains was used as criterion 4 (see Supplementary data, available at JAC Online).

A transmission was considered *possible* when criterion 1 was fulfilled. In contrast, a transmission was considered *probable* when criterion 2 or 3 was fulfilled. Fulfilment of criterion 4 alone was regarded as a *probable* transmission. A transmission between patient A and B was rated as *predicted* when criterion 4 was fulfilled in combination with any of the three epidemiological criteria. If no criterion was fulfilled, the transmission probability was considered unknown. The TPS algorithm was applied by two independent investigators.

Results and discussion

Outbreak setting and interventions

The University Hospital Tübingen is a 1500 bed tertiary teaching hospital with two major wards for the treatment of patients with haematological–oncological diseases. The outbreak occurred on both wards. Ward 1 is a general ward with double rooms. Ward 2 is an ICU for patients receiving stem cell transplantations and consists of single rooms.

The index patient was diagnosed with *P. aeruginosa* bloodstream infection in July 2009 on ward 1 (Figure 1). The isolate was resistant to all antimicrobial agents tested except colistin, revealing an XDR phenotype according to the ECDC/CDC definition.³ A second patient experienced bacteraemia in November 2009 on the same ward, exhibiting again an XDR-PA with the same susceptibility pattern. At that time, the two cases were considered epidemiologically unrelated. However, new cases in the second quarter of 2010 and the increasing incidence in the third quarter pointed to an outbreak. Therefore, an investigation by the infection control team was launched. The initial programme of targeted measures included enhanced emphasis on hand hygiene, a programme of deep room cleaning, the introduction of a weekly screening programme and screening at admission, and the installation of an isolation zone with three rooms on ward 1, where infected or colonized patients were treated by medical staff who were not allowed to work in other ward areas on the same day.

The incidence of XDR-PA remained high at the beginning of 2011 despite the implementation of the initial infection control programme, suggesting that contaminated environmental sources could sustain the outbreak (Figure S1). Isolation of XDR-PA from siphon water at that time indicated that the outbreak was associated with colonization of washing basins. This led to the replacement of all siphons under washing basins and the simultaneous installation of a fully automated cleaning device for thermal disinfection ($85–93^{\circ}\text{C}$) and vibration cleaning (50 Hz) of the new siphons to prevent biofilm formation. The number of new XDR-PA cases dropped following these interventions and remained at an average baseline level of one new case per quarter at the time of submission, reflecting the transformation from an epidemic into an endemic state. A full list of interventions is summarized in Table S1.

Core genome investigation

Forty-one XDR-PA isolates from 26 patients were collected for genome sequencing between July 2009 and March 2012, spanning the peak of the outbreak in the first quarter of 2011

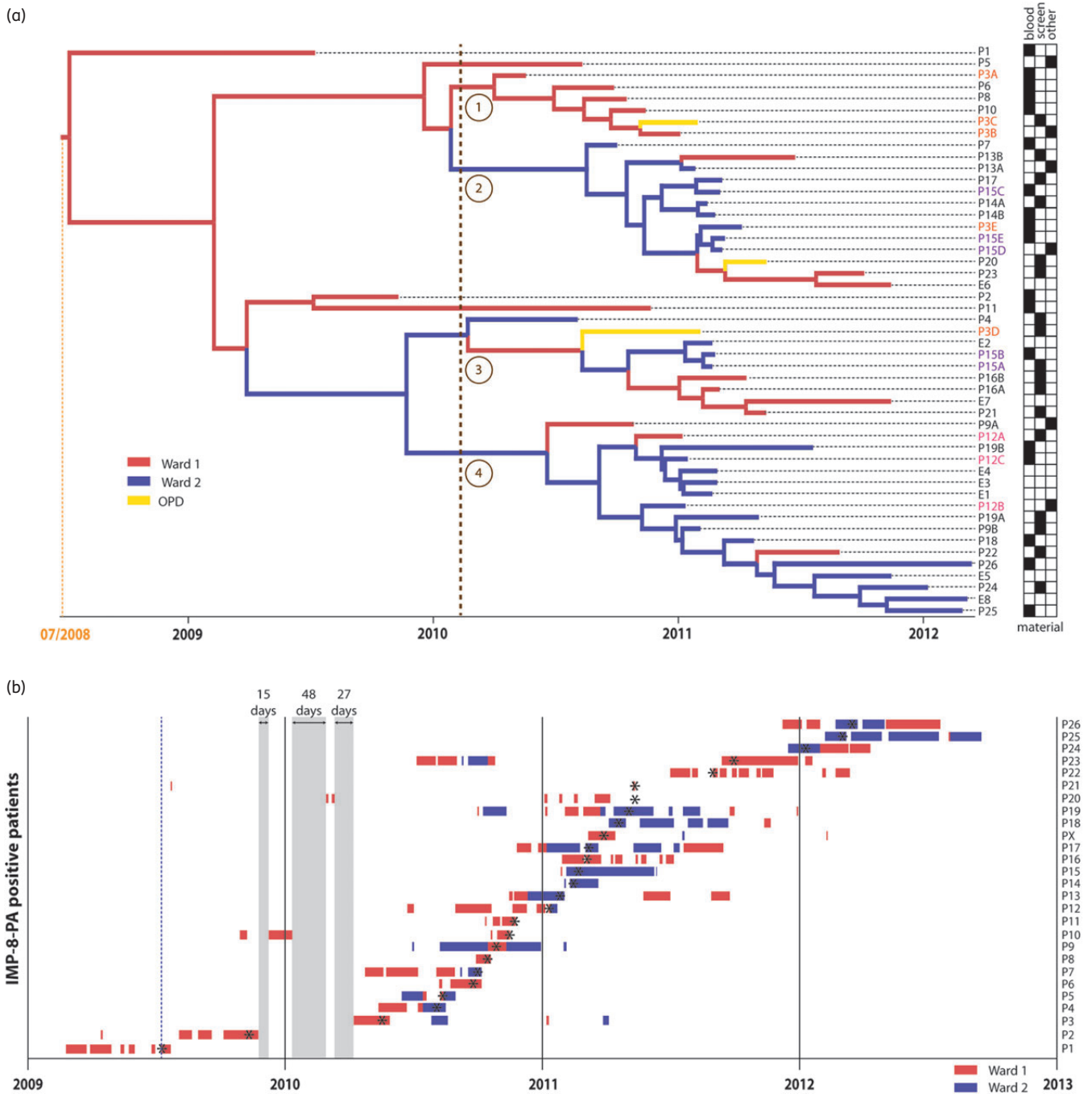

Figure 1. Bayesian phylogenetic reconstruction with location, divergence date estimation and epidemiological data on 49 *P. aeruginosa* (PA) outbreak isolates. (a) Tree structure is based on a Bayesian phylogenetic statistical approach constructed from the core genome alignment, which includes 22 outbreak-specific SNPs. The node and branch colours present the known (leaves) and predicted (internal branches) locations of the isolates. OPD stands for outpatient department. The brown numbers indicate the four major clades that emerged at the beginning of 2010, with a brown dashed line at the beginning of the clades. The orange dashed line marks the temporal origin of the tree in July 2008. Strains from patients with more than two study isolates are coloured. The material from which the strain was cultured is displayed in the box on the right. Screening materials for *P. aeruginosa* were pharyngeal and rectal swabs and stool samples. Patient isolates start with a 'P' while environmental isolates start with an 'E'. (b) Epidemiological map of 27 patients on two wards in the haematology department. The strain of patient x (PX) was not available for sequencing. Red and blue indicate a stay in ward 1 and 2, respectively. The asterisk indicates the first record of a patient's outbreak isolate. The blue dashed line represents the start of the outbreak. Grey vertical blocks display times when there were no known carriers of the outbreak strain on either ward.

Table 1. Twenty-four core genome SNPs of 49 *P. aeruginosa* outbreak isolates; the specified SNP substitutions relate to the reference genome WGS-E4

Core SNP position	Region	Enzyme code	Isolates	SNP	Substitution
226279 ^a	—	—	P4	T→C	intergenic
393592	permease	—	P4	A→G	Phe187Ser
437952	CheW-like domain protein	EC:2.7.3	E3	C→T	synonymous
632368 ^a	phage tail protein	—	P3A, P6, P11, P3B, P13A, P3C, P3D, P14A, P15A, E2, P15B, P14B, P16A, P15C, P15D, P15E, P3E, P16B, P13B	G→A	synonymous
1000582	porin D (OprD)	—	P1, P2, P3A, P4, P5, P6, P7, P8, P10, P11, P3B, P13A, P3C, P3D, P14A, P15A, E2, P15B, P14B, P16A, P15C, P17, P15D, P15E, P3E, P16B, P20, P21, P13B, P23, E6, E7	T→C	Asp106Gly
1063891	—	—	P6	G→A	intergenic
1069103	transcriptional regulator	EC:3.6.1.15	P16B	T→G	Val270Gly
1104673	Mfs family transporter	—	P14A, P14B	T→G	His160Pro
1315012	ABC-type antimicrobial peptide transport ATPase component	—	P11, E6	C→G	synonymous
1537804	lipoprotein	—	P25	G→A	Ser57Leu
1913494	anaerobic ribonucleoside-triphosphate reductase (NrdD)	EC:1.17.4.2	P1, P2, P4, P9A, P11, P12B, P9B, P3D, P15A, E2, P15B, P16A, P16B, P18, P19A, P21, P22, E5, E7, P24, P26	C→A	Gly124Val
2389760	ABC transporter ATP-binding protein	EC:3.6.1.3	P19B	A→G	Glu148Gly
2684713	chemotaxis transducer	—	P15C	C→G	Ile376Met
3239794	—	—	P13A, P13B	T→C	intergenic
4049373	pyochelin synthetase (PchF)	—	P1, P3B, P3C, E5	C→A	synonymous
4103474	DNA-directed RNA polymerase subunit β (RpoB)	EC:2.7.7.6	P16B	T→A	Gln152Leu
4867436	—	—	P25	G→T	intergenic
4972016	spermidine putrescine ABC transporter substrate-binding protein	—	P3C, P3D	G→A	synonymous
5236482	—	—	P2	G→C	intergenic
5272104	exodeoxyribonuclease III	EC:3.1.11.2	E5, P24, P25, E8	A→C	Thr225Pro
5577991	—	—	P12B	C→A	intergenic
5660814	transcriptional regulator	—	P26	T→C	Leu69Pro
5740900	—	—	P11	A→T	intergenic
5749062	hypothetical protein	—	P2, P5, P11, E1, P19A	G→T	synonymous

^aThese SNPs were removed for phylogenetic analysis.

(Figure S1). Additionally, we sequenced eight outbreak strains isolated from siphon water, washing basins and toilet siphons on both wards. All isolates carried an IMP-8 gene and belonged to ST308 (by MLST), suggesting a clonal occurrence. Details of all 49 outbreak isolates are listed in Table S2.

Twenty-four outbreak-specific core genome SNPs were detected when using WGS-E4 as reference. A total of 17 SNPs were located in gene regions, 11 of which cause amino acid changes. Seven SNPs were located in intergenic regions (Table 1).

Phylogeny of the outbreak strains

Prior to phylogenetic analysis we generated a non-recombinant core genome by detecting regions of recombinant origin using BratNextGen²⁴ and regions with prophage content using PHAST.²⁵ The removal of regions of recombinant origin resulted in the loss of one SNP at genome position 226279. Another SNP at genome position 632368 was additionally removed because

of its location in a phage tail protein. The final non-recombinant core genome, with a length of 5 823 688 bp, contained 22 SNPs and was used for phylogenetic analysis.

We applied Bayesian statistics to infer a time-measured phylogeny (Figure 1a). The analysis revealed a strong phylogeographic structure with its root location on ward 1 with a 90.7% probability. At the beginning of 2010 the tree split into four major clades spreading mainly over one ward, except clade 3, which extended over both wards. These results are in agreement with the hypothesis that sub-lineages of outbreak strains develop independently and are transmitted within their predominant location, although some isolates were occasionally introduced to the non-clade-related ward, most likely due to frequent patient transferrals between the two wards, as reflected in the epidemiological map (Figure 1b). Of note, multiple isolates sampled from the same patient over a short interval could belong to different clades, indicating intra-individual strain variation that could hamper transmission analysis, since one patient could transmit more than one variant simultaneously at any given

timepoint. In addition, analysis is hampered by the possibility of multiple transmissions to one patient, which was the case in patient 3. In May 2010, this patient was initially detected positive on ward 1 with an isolate that belonged to clade 1 (P3A). In February 2011, an isolate (P3D) was sampled that was associated with clade 3 and was possibly transmitted in the outpatient department. Maximum-likelihood phylogeny (Figure S2), the minimum spanning tree of the outbreak (Figure S3) and the SeqTrack algorithm (Figure S4) illustrate similar results.

Based on the Bayesian analysis, the median mutation rate was estimated to be 2.02×10^{-7} SNPs/bp/year [95% highest posterior density interval (HPD) 9.83×10^{-8} – 3.18×10^{-7} SNPs/bp/year]. This is equivalent to 1.18 SNPs/year (95% HPD 0.57–1.85 SNPs/year), which is in the range of previous estimates for *P. aeruginosa*,^{26,27} but significantly lower than for *Staphylococcus aureus* (1 SNP per 6 weeks).¹¹ The low mutation rate is likely the reason why many nodes in the maximum-likelihood phylogeny remain weakly supported. It is uncertain whether this lower discriminatory power would provide enough resolution for tracing transmission routes in *P. aeruginosa* outbreaks that span a shorter time period or examine fewer isolates than our study.

Applying Bayesian statistics, we have estimated that the most recent common ancestor of the outbreak dates to July 2008 (95% HPD October 2006 to May 2009).

Temporal origin of the outbreak

Assuming that an individual is exposed to only one variant, July 2008 could represent the timepoint when the unknown primary patient became a carrier. It is possible that this primary patient stayed regularly on ward 1 for up to 1 year before the index case emerged, posing a permanent, but hidden, threat to immunocompromised high-risk patients. Another scenario is also possible. Most metallo- β -lactamases genes, like IMP-8, are inserted in integron regions along with other determinants of resistance and can thus transfer along with mobile DNA elements associated with such integrons (plasmids and transposons).²⁸ In fact, IMP-8 has recently been discovered on a plasmid in a clinical strain of *Citrobacter freundii*, which potentially enables it to be horizontally transferred to other species in our hospital.²⁹ It is thus conceivable that the ST308 strain has acquired the IMP-8 gene from an environmental, perhaps unculturable, strain approximately in July 2008 or within the time range of the 95% HPD. The new resistant strain could have remained hidden in the waste-water system, and some patients might have been already colonized before the index case became apparent with a severe bloodstream infection in July 2009. Witney et al.³⁰ have found a susceptible *P. aeruginosa* clinical isolate highly similar to XDR isolates that appeared 6 years later in the context of an outbreak, showing that such a scenario is possible.

Reconstruction of transmission routes

We have investigated whether information about genetic relatedness based on SNP data could improve tracing of transmission routes in addition to epidemiological information gained by conventional surveillance methods. The probability of transmission was estimated by the TPS algorithm. Using the epidemiological criteria alone, transmission between patients was considered possible in 23 cases (Figure 2a, blue arrows) and probable in three

cases (Figure 2a, brown arrows). Information gained from SNP data considerably advanced the understanding of transmission routes at outbreak onset (Figure 2b, orange arrows). It revealed seven additional cases of probable transmission where no transmission was suspected based on the epidemiological criteria alone. Figure 2(c) shows transmission probabilities when using the TPS algorithm by combining epidemiological and genetic criteria. Three transmissions that had been scored as possible or probable based on epidemiological criteria alone could be predicted with a high probability by additionally applying the genetic criterion (Figure 2c, pink arrows). Looking at two of these cases, it can be noted that the patients stayed on ward 1 at the same time, but not in the same room (patient 3→patient 7 and patient 9→patient 12). This is indicative of transmission via medical personnel. In the third case two patients shared the same room (criterion 3), and transmission could have occurred via personnel, direct patient contact or environmental contamination (patient 8→patient 10). Surprisingly, the probable transmissions from patients 6 and 9 to patient 11, who had stayed in the same room in a consecutive order (criterion 2), were not confirmed by genetic data, suggesting that environmental contamination cannot always be assumed as the transmission route in such a situation. However, a transmission might have taken place despite the genetic distance of the isolates. Sampling more isolates of patient 6 or 9 could have revealed a strain more closely related to the strain of patient 11. Thus, we still scored the transmission as probable due to the valid epidemiological criterion.

Another interesting discovery was the genetic distance between the isolates of patients 1 and 2, which differed by three SNPs. Given the estimated mutation rate, it is unlikely that the potential descendant strain of patient 1 could have evolved so fast in the short period between the samplings of the two strains. We hypothesize that more than one variant was already circulating during the early phase of the outbreak, potentially introduced by an unknown primary patient who became colonized some time before admission to the hospital. The circulation of different variants in the early phase of the outbreak could account for the weak correlation between the accumulation of SNPs since the first outbreak isolate and time (Pearson correlation=0.34, $P=0.017$).

Figure 3 illustrates probabilities of transmission routes for all outbreak patients between 2009 and 2012 based on the TPS algorithm. In contrast to the isolate of patient 2, which was not further transmitted, we identified three potential superspreaders with a high number of probable or predicted transmissions (patients 3, 7 and 9). The presence of superspreaders was confirmed by using the SeqTrack algorithm, which has recently been proposed for tracing transmission routes with genomic data³¹ (Figure S4).

An example of particular interest is the probable transmission between patients 1 and 21. In 2009, patient 21 stayed in a room for 3 days directly after patient 1. In 2011, an outbreak strain was isolated from a rectal swab of patient 21 only 2 days after readmission (Figure 1b). The isolate differed from the strain of patient 1 in only one SNP. We have also obtained isolates from patients 15 and 16 that were genetically identical to the strain of patient 21, but the absence of any epidemiological link makes a transmission via patients 15 and 16 less likely. This indicates that a transmission could have already occurred in 2009 and that the outbreak strain established a stable colonization in a host for almost 2 years.

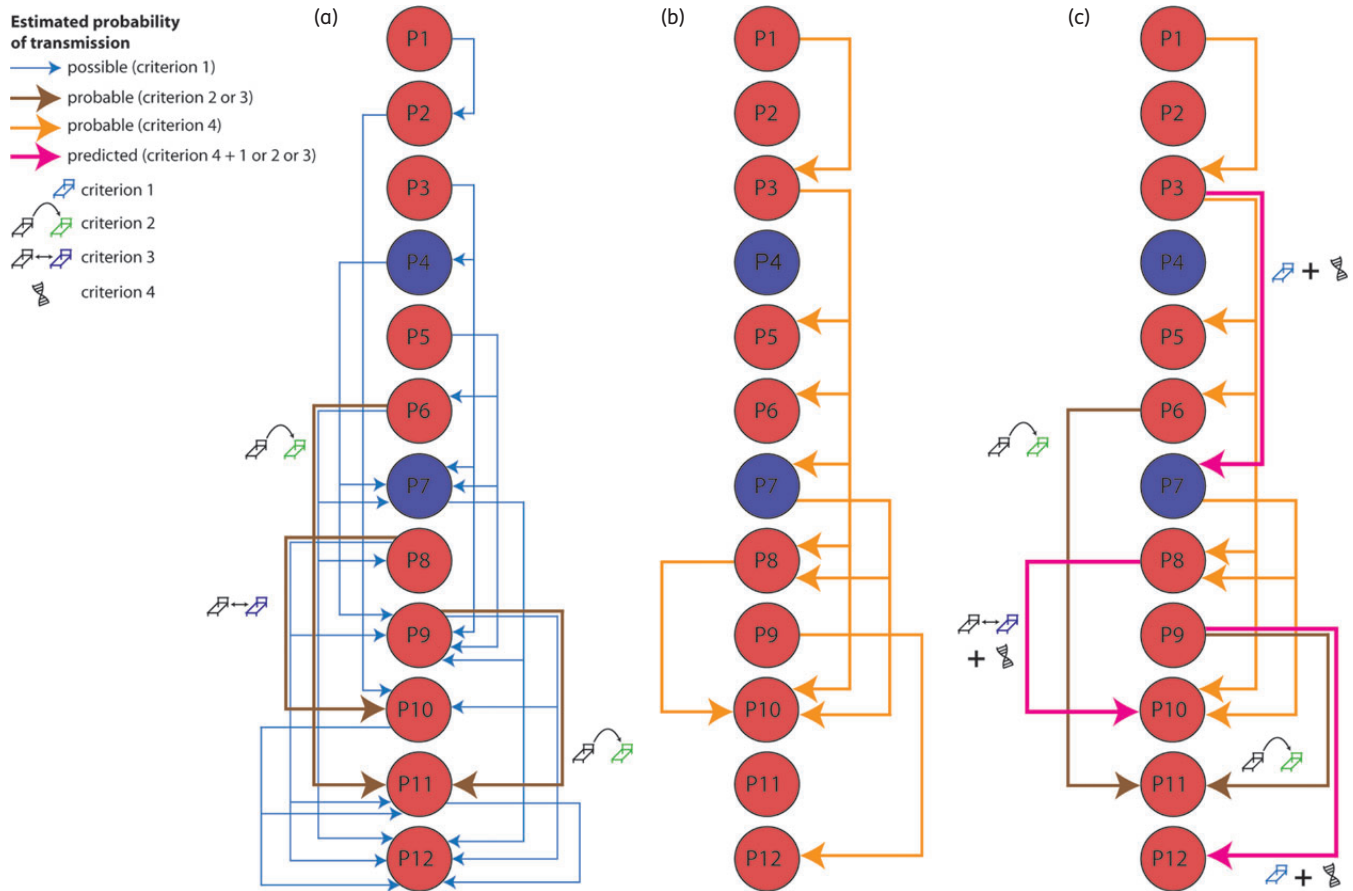

Figure 2. Estimated probability of transmission routes for the first 12 patients involved in the outbreak. Each patient is outlined as a circle. The colour of the circle indicates the patient’s location at the first finding of the outbreak isolate. Red stands for ward 1 and blue for ward 2. The line colour and thickness reflect the estimated strength of transmission probability between two patients. Criteria 1–4 are described in detail in the Materials and methods section (and in the Supplementary data). Briefly: criterion 1, same ward, same time; criterion 2, same room consecutively within 14 days; criterion 3, same room, same time; and criterion 4, close genetic relatedness. The presence of criteria is indicated by symbols close to the line of transmission between two patients. (a) Probability of transmission based on the three epidemiological criteria alone. (b) Probability of transmission based on the genetic relatedness criterion alone. (c) Probability of transmission based on the three epidemiological criteria in combination with the genetic relatedness criterion (TPS algorithm). Only *probable* and *predicted* transmissions are shown. *Possible* transmissions were graphically omitted to focus on the major transmission probabilities.

Another predicted relation was found between patients 15 and 17. The single isolate of patient 17 had a core genome identical to that of a late isolate of patient 15 (P15D). Both isolates were obtained within 3 days. The small time gap caused uncertainty regarding the direction of transmission, but points to the possibility that patients that tested positive for the outbreak strain could have transmitted their strain variants to patients whose carrier status was detected earlier. This assumption appears even more likely in the light of long and hidden colonizations, as has been suggested for patient 21, and shows that patients can be exposed multiple times and can be colonized with different variants of an outbreak strain. This complexity of transmission is missed when only one isolate per individual is obtained.

Factors involved in sustainment of the outbreak

The recovery of eight outbreak isolates from the waste-water system and washing basins proved that contamination of the

hospital environment had occurred and indicated the presence of potential reservoirs for IMP-8 XDR-PA. Outbreak strains were also sampled from the inner surface of siphons after their removal and replacement, demonstrating biofilm formation. Especially alarming was the finding of environmental strain E4 in siphon water from a room 5 weeks after two genetically identical clinical isolates were recovered from patient 12 while the patient stayed in this room (P12A and P12C). At that time a deep cleaning programme with regular application of tube cleaners had already been initiated. This highlights the problems associated with inefficient eradication of biofilms and indicates that environmental contamination can act as a reservoir for recurrent exposure of patients and sustain hospital outbreaks with *P. aeruginosa*.

This is supported by the fact that the core nucleotide diversity of the environmental samples ($\pi=4.48 \times 10^{-7}$, $SE=1.28 \times 10^{-7}$) was 97% of the total for all isolates ($\pi=4.62 \times 10^{-7}$, $SE=1.46 \times 10^{-7}$). The finding that the majority of the overall diversity was present in the small environmental subset suggests a dynamic exchange

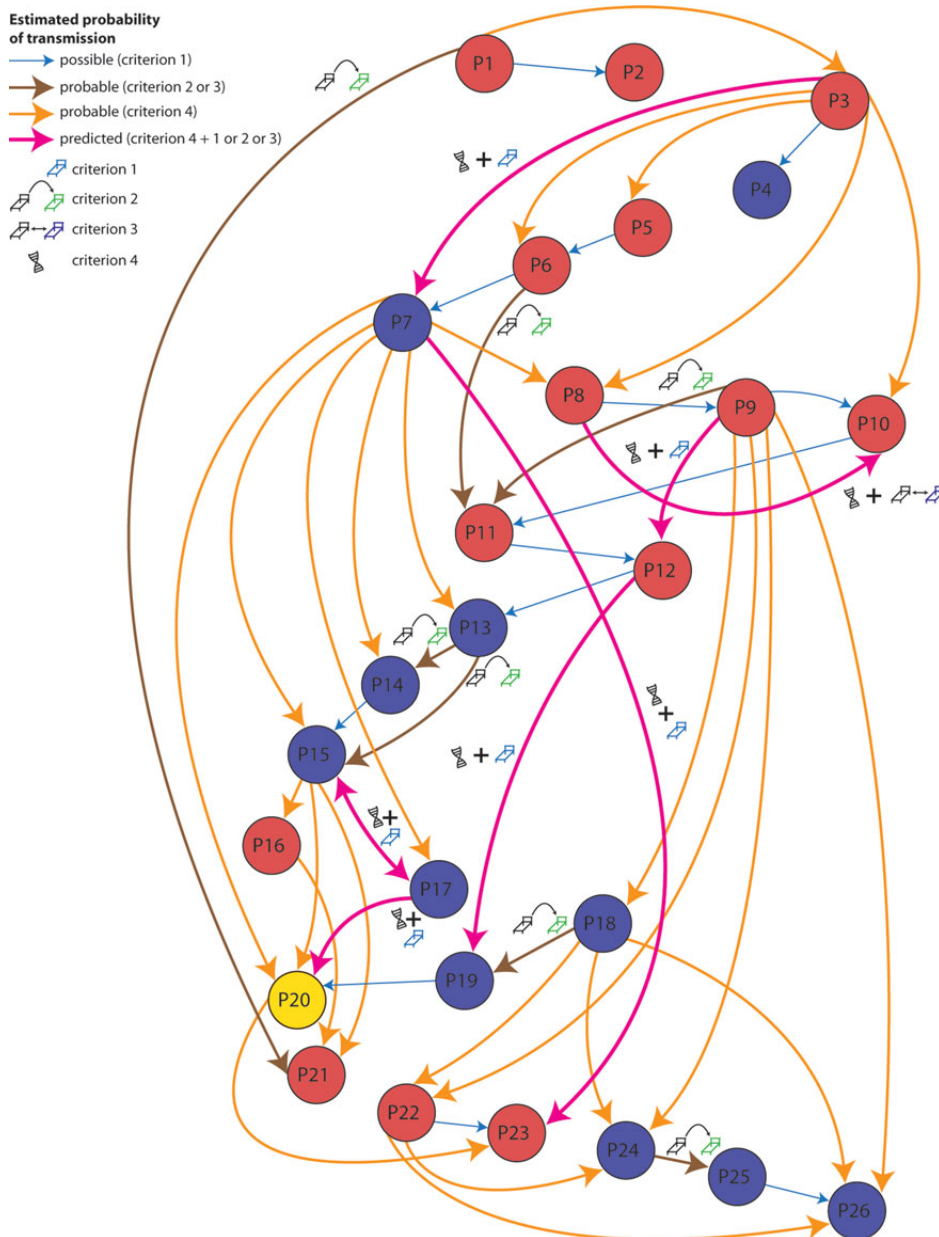

Figure 3. Estimated probability of transmission routes for 26 outbreak patients using the TPS algorithm. Each patient is outlined as a circle. The colour of the circle indicates the patient’s location at the first finding of the outbreak isolate. Red stands for ward 1, blue stands for ward 2 and yellow stands for the outpatient department. The line colour and thickness reflect the estimated strength of the transmission probability between two patients. Criteria 1–4 are described in detail in the Materials and methods section (as well as in the Supplementary data). Briefly: criterion 1, same ward, same time; criterion 2, same room consecutively within 14 days; criterion 3, same room, same time; and criterion 4, close genetic relatedness. The presence of criteria is indicated by symbols in close proximity to the line of transmission between two patients.

between patients and the environment, supporting the hypothesis that the outbreak was sustained by environmental contamination. This was confirmed by the low degree of population differentiation between the patient and environmental subset (coefficient of differentiation=0.017, SE=0.079).

Outbreak-specific SNPs represent strain evolution over the duration of the outbreak and possibly an adaption to hospital-related factors. The gene sequence changes found in *oprD* and *nrdD* were

of particular interest as they occurred in more than one isolate (Table 1). *OprD* is an outer membrane protein and functions as a common channel for the intake of amino acids and peptides as well as carbapenem antibiotics.^{32,33} Structural changes in *OprD* have been associated with a decrease in carbapenem susceptibility.^{34,35} Another study investigated the fitness of 300 000 *P. aeruginosa* PA14 transposon insertion mutants in mice. *oprD* mutants were identified that not only revealed increased

carbapenem resistance, but were also associated with enhanced fitness for mucosal colonization and with systemic spread. Other *oprD* mutants demonstrated elevated resistance to acid pH and increased cytotoxicity against macrophages. Furthermore, exposure to human serum killed some *oprD* mutants to a lesser extent, which indicated that OprD might act as a crucial factor for the establishment of bacteraemia.³⁶ It has also been reported that OprD can be sialylated, leading to a reduction in complement deposition on the bacterium when incubated with human serum.³⁷

Another variation has been observed in the *nrdD* gene, which encodes a ribonucleotide reductase enzyme (RNR). The three classes of RNRs are responsible for the conversion of nucleoside 5'-di- or triphosphates into deoxyribonucleotides, which are essential for DNA synthesis and DNA repair. NrdD belongs to the class III RNRs, and it has been shown that NrdD is of crucial importance for anaerobic growth of *P. aeruginosa*. Growth under such anaerobic conditions results in elongated *P. aeruginosa* bacilli, which show robust biofilm formation.^{38,39}

Since OprD plays a role in strain survival and pathogenic capability and NrdD facilitates anaerobic growth and is potentially involved in biofilm establishment, mutations in their genes could reflect an evolutionary development in response to clinical or environmental stress within the hospital.

Effectiveness of infection control measures

In spite of the success of our infection control interventions, which transformed the epidemic into an endemic situation, it is debatable whether regular active screening cultures (ASCs) for *P. aeruginosa* in haematological–oncological patients should be a recommended practice. Recently, we have observed an overall in-hospital mortality of 38% in patients with *P. aeruginosa* bloodstream infections, but we could not verify that metallo- β -lactamase production and MDR phenotype are independent predictors of mortality.⁴⁰ Our study indicates that, although the impact of MDR-PA on mortality in serious infections is still a controversial topic,⁴¹ it would be of great interest to focus infection control measures on the prevention of any infection with *P. aeruginosa*, regardless of the susceptibility pattern. Despite the lack of evidence that ASCs are an effective measure in endemic settings with MDR-PA,⁴² it is safe to assume that early detection of increasing rates of otherwise hidden long-term carriers makes it possible to take action before high-risk patients acquire severe infections, possibly during an outbreak situation.

Acknowledgements

We thank the director, physicians, laboratory and nursing staff of the involved medical wards. We further extend our gratitude to Kerstin Fischer and Nadine Hoffmann for their assistance in laboratory testing and analysis and thank Robert Schlager and Liam Whiteley for helpful discussions regarding the manuscript.

Funding

This work was supported by a grant from 'la Caixa' to L. Z. The funder had no role in study design, data collection and analysis, decision to publish or preparation of the manuscript.

Transparency declarations

None to declare.

Supplementary data

Supplementary data, including Figures S1 to S4 and Tables S1 and S2, are available as Supplementary data at JAC Online (<http://jac.oxfordjournals.org/>).

References

- 1 ECDC. *Point Prevalence Survey of Healthcare-Associated Infections and Antimicrobial Use in European Acute Care Hospitals*. 2013. <http://www.ecdc.europa.eu/en/publications/Publications/healthcare-associated-infections-antimicrobial-use-PPS.pdf>.
- 2 ECDC. *Antimicrobial Resistance Surveillance in Europe 2012. Annual Report of the European Antimicrobial Resistance Surveillance Network (EARS-Net)*. 2013. <http://ecdc.europa.eu/en/publications/Publications/antimicrobial-resistance-surveillance-europe-2012.pdf>.
- 3 Magiorakos AP, Srinivasan A, Carey RB *et al*. Multidrug-resistant, extensively drug-resistant and pandrug-resistant bacteria: an international expert proposal for interim standard definitions for acquired resistance. *Clin Microbiol Infect* 2012; **18**: 268–81.
- 4 Aloush V, Navon-Venezia S, Seigman-Igra Y *et al*. Multidrug-resistant *Pseudomonas aeruginosa*: risk factors and clinical impact. *Antimicrob Agents Chemother* 2006; **50**: 43–8.
- 5 Tam VH, Rogers CA, Chang KT *et al*. Impact of multidrug-resistant *Pseudomonas aeruginosa* bacteremia on patient outcomes. *Antimicrob Agents Chemother* 2010; **54**: 3717–22.
- 6 Tumbarello M, Repetto E, Trecarichi EM *et al*. Multidrug-resistant *Pseudomonas aeruginosa* bloodstream infections: risk factors and mortality. *Epidemiol Infect* 2011; **139**: 1740–9.
- 7 Morales E, Cots F, Sala M *et al*. Hospital costs of nosocomial multi-drug resistant *Pseudomonas aeruginosa* acquisition. *BMC Health Serv Res* 2012; **12**: 122.
- 8 Corvec S, Poirel L, Espaze E *et al*. Long-term evolution of a nosocomial outbreak of *Pseudomonas aeruginosa* producing VIM-2 metallo-enzyme. *J Hosp Infect* 2008; **68**: 73–82.
- 9 Snyder LA, Loman NJ, Faraj LA *et al*. Epidemiological investigation of *Pseudomonas aeruginosa* isolates from a six-year-long hospital outbreak using high-throughput whole genome sequencing. *Euro Surveill* 2013; **18**: pii=20611.
- 10 Loveday HP, Wilson JA, Kerr K *et al*. Association between healthcare water systems and *Pseudomonas aeruginosa* infections: a rapid systematic review. *J Hosp Infect* 2014; **86**: 7–15.
- 11 Harris SR, Feil EJ, Holden MT *et al*. Evolution of MRSA during hospital transmission and intercontinental spread. *Science* 2010; **327**: 469–74.
- 12 Koser CU, Holden MT, Ellington MJ *et al*. Rapid whole-genome sequencing for investigation of a neonatal MRSA outbreak. *N Engl J Med* 2012; **366**: 2267–75.
- 13 Gardy JL, Johnston JC, Ho Sui SJ *et al*. Whole-genome sequencing and social-network analysis of a tuberculosis outbreak. *N Engl J Med* 2011; **364**: 730–9.
- 14 Snitkin ES, Zelazny AM, Thomas PJ *et al*. Tracking a hospital outbreak of carbapenem-resistant *Klebsiella pneumoniae* with whole-genome sequencing. *Sci Transl Med* 2012; **4**: 148ra116.
- 15 Nubel U, Roumagnac P, Feldkamp M *et al*. Frequent emergence and limited geographic dispersal of methicillin-resistant *Staphylococcus aureus*. *Proc Natl Acad Sci USA* 2008; **105**: 14130–5.

- 16 EUCAST. *Breakpoint Tables for Interpretation of MICs and Zone Diameters*. 2012. http://www.eucast.org/fileadmin/src/media/PDFs/EUCAST_files/Breakpoint_tables/Breakpoint_table_v_2.0_120221.pdf.
- 17 EUCAST. *Antimicrobial Susceptibility Testing—EUCAST Disk Diffusion Method Version 4.0*. 2014. http://www.eucast.org/fileadmin/src/media/PDFs/EUCAST_files/Disk_test_documents/Version_4/Manual_v_4.0_EUCAST_Disk_Test.pdf.
- 18 Leclercq R, Canton R, Brown DF et al. EUCAST expert rules in antimicrobial susceptibility testing. *Clin Microbiol Infect* 2013; **19**: 141–60.
- 19 Clinical and Laboratory Standards Institute. *Performance Standards for Antimicrobial Susceptibility Testing: Twenty-third Informational Supplement M100-S23*. CLSI, Wayne, PA, USA, 2013.
- 20 Luo R, Liu B, Xie Y et al. SOAPdenovo2: an empirically improved memory-efficient short-read de novo assembler. *Gigascience* 2012; **1**: 18.
- 21 Darling AE, Mau B, Perna NT. progressiveMauve: multiple genome alignment with gene gain, loss and rearrangement. *PLoS One* 2010; **5**: e11147.
- 22 Langmead B, Salzberg SL. Fast gapped-read alignment with Bowtie 2. *Nat Methods* 2012; **9**: 357–9.
- 23 Li H, Handsaker B, Wysoker A et al. The Sequence Alignment/Map format and SAMtools. *Bioinformatics* 2009; **25**: 2078–9.
- 24 Marttinen P, Hanage WP, Croucher NJ et al. Detection of recombination events in bacterial genomes from large population samples. *Nucleic Acids Res* 2012; **40**: e6.
- 25 Zhou Y, Liang Y, Lynch KH et al. PHAST: a fast phage search tool. *Nucleic Acids Res* 2011; **39**: W347–52.
- 26 Marvig RL, Johansen HK, Molin S et al. Genome analysis of a transmissible lineage of *Pseudomonas aeruginosa* reveals pathoadaptive mutations and distinct evolutionary paths of hypermutators. *PLoS Genet* 2013; **9**: e1003741.
- 27 Yang L, Jelsbak L, Marvig RL et al. Evolutionary dynamics of bacteria in a human host environment. *Proc Natl Acad Sci USA* 2011; **108**: 7481–6.
- 28 Cornaglia G, Giamarellou H, Rossolini GM. Metallo- β -lactamases: a last frontier for β -lactams? *Lancet Infect Dis* 2011; **11**: 381–93.
- 29 Peter S, Wolz C, Kaase M et al. Emergence of *Citrobacter freundii* carrying IMP-8 metallo- β -lactamase in Germany. *New Microbes New Infect* 2013; **2**: 42–5.
- 30 Witney AA, Gould KA, Pope CF et al. Genome sequencing and characterization of an extensively drug-resistant sequence type 111 serotype O12 hospital outbreak strain of *Pseudomonas aeruginosa*. *Clin Microbiol Infect* 2014; **20**: O609–18.
- 31 Jombart T, Eggo RM, Dodd PJ et al. Reconstructing disease outbreaks from genetic data: a graph approach. *Heredity (Edinb)* 2011; **106**: 383–90.
- 32 Trias J, Nikaido H. Outer membrane protein D2 catalyzes facilitated diffusion of carbapenems and penems through the outer membrane of *Pseudomonas aeruginosa*. *Antimicrob Agents Chemother* 1990; **34**: 52–7.
- 33 Trias J, Nikaido H. Protein D2 channel of the *Pseudomonas aeruginosa* outer membrane has a binding site for basic amino acids and peptides. *J Biol Chem* 1990; **265**: 15680–4.
- 34 Ochs MM, Bains M, Hancock RE. Role of putative loops 2 and 3 in imipenem passage through the specific porin OprD of *Pseudomonas aeruginosa*. *Antimicrob Agents Chemother* 2000; **44**: 1983–5.
- 35 Huang H, Jeanteur D, Pattus F et al. Membrane topology and site-specific mutagenesis of *Pseudomonas aeruginosa* porin OprD. *Mol Microbiol* 1995; **16**: 931–41.
- 36 Skurnik D, Roux D, Cattoir V et al. Enhanced in vivo fitness of carbapenem-resistant oprD mutants of *Pseudomonas aeruginosa* revealed through high-throughput sequencing. *Proc Natl Acad Sci USA* 2013; **110**: 20747–52.
- 37 Khatua B, Vleet JV, Choudhury BP et al. Sialylation of outer membrane porin protein D: a mechanistic basis of antibiotic uptake in *Pseudomonas aeruginosa*. *Mol Cell Proteomics* 2014; **13**: 1412–28.
- 38 Sjoberg BM, Torrents E. Shift in ribonucleotide reductase gene expression in *Pseudomonas aeruginosa* during infection. *Infect Immun* 2011; **79**: 2663–9.
- 39 Lee KM, Go J, Yoon MY et al. Vitamin B12-mediated restoration of defective anaerobic growth leads to reduced biofilm formation in *Pseudomonas aeruginosa*. *Infect Immun* 2012; **80**: 1639–49.
- 40 Willmann M, Kuebart I, Marschal M et al. Effect of metallo- β -lactamase production and multidrug resistance on clinical outcomes in patients with *Pseudomonas aeruginosa* bloodstream infection: a retrospective cohort study. *BMC Infect Dis* 2013; **13**: 515.
- 41 Vardakas KZ, Rafailidis PI, Konstantelias AA et al. Predictors of mortality in patients with infections due to multi-drug resistant Gram negative bacteria: the study, the patient, the bug or the drug? *J Infect* 2013; **66**: 401–14.
- 42 Tacconelli E, Cataldo MA, Dancer SJ et al. ESCMID guidelines for the management of the infection control measures to reduce transmission of multidrug-resistant Gram-negative bacteria in hospitalized patients. *Clin Microbiol Infect* 2014; **20**: 1–55.